

instruction manual Monopoints

NOTE

Low voltage transformers should ideally be located as close to the luminaires or track systems as possible. Always use at least the minimum power feed cable size detailed on the transformer spec sheet. As standard 4mm diameter cable can be used for Monopoint systems. Calculate the voltage drop for each individual system, and if necessary use a larger cable size. Access to serviceable electrical components should be possible at all times for maintenance purposes.



IMPORTANT SAFETY INFORMATION

READ ALL INSTRUCTIONS BEFORE USING THESE PRODUCTS. SAVE THESE INSTRUCTIONS FOR LATER REFERENCE.

1. Mains supply to driver must be OFF before connecting or disconnecting the fittings.
2. Must be installed by a suitably qualified professional only. Installations must conform with standard accepted electrical installation practices, local codes and ordinances.
3. Do not install any fixture closer than 150mm (6 inches) from any combustible material. Do not install these systems in a damp or wet location.
4. To reduce the risk of fire and burns, do not install these systems where exposed bare conductors can be shorted or contact any conductive materials. Do not conceal or extend exposed conductors through a building wall.
5. No part of the secondary circuit should be earthed.
6. All electrical connections must be tight, especially those on the secondary side of the power supply (low voltage side). Bad connections can cause overheating, arcing and a potential fire risk.
7. Install only as described in this Precision Lighting manual. Appropriate fixings will need to be used depending on surface material at the installer's discretion.
8. Connect only Precision Lighting luminaires fitted with jack plug adaptor.
9. Ensure that the system is switched off at mains supply before touching.
10. Connected luminaires may be extremely hot, allow to cool before touching.
11. All monopoints must be connected to an appropriate PSU with the exception of the Power Monopoint which has an integral transformer.
12. Regular cleaning of these products is important. Switch off at mains supply and allow to cool before touching. Clean fittings with microfibre cloth. Then reconnect the power supply.
13. Wire supply connections must be made with U.L or compatible testing agency-approved connectors.

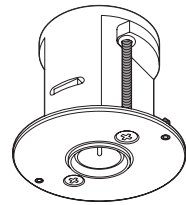

trimless monopoint [MPS]

LV Rating 75W at 12V

LED Rating 150W at 24V

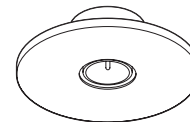

flat monopoint [MPX]

LV Rating 75W at 12V

LED Rating 150W at 24V

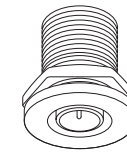

node monopoint [MPY]

LV Rating 75W at 12V

LED Rating 150W at 24V

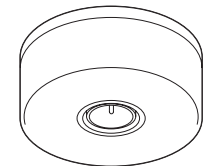

surface monopoint [MPZ]

LV Rating 75W at 12V

LED Rating 150W at 24V

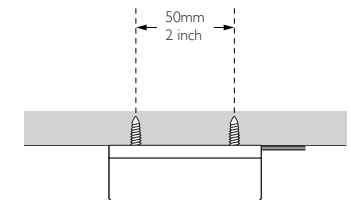
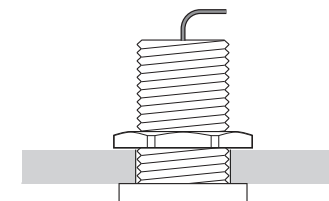
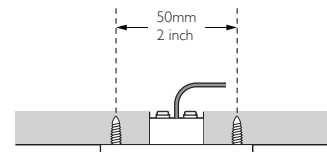
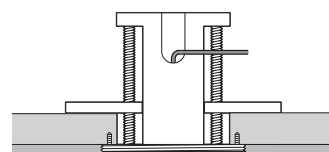

1. Trimless Monopoint [MPS].

IMPORTANT Trimless Monopoint must be installed before plastering unless using decorative canopy (sold separately).

- Wire-up using blue crimp not terminal block.
- Stow retaining arms and insert monopoint in $\text{\O}45\text{mm}$ (1-13/16") ceiling hole.
- Turning locking screws causes retaining arms to expand. Pointed set-screws will grip ceiling material. Continue screwing until Monopoint is secured.
- Rotate connector ring to adjust height depending on plaster thickness.
- Cover with plaster mesh and apply plaster to finish or, alternatively, use decorative canopy.

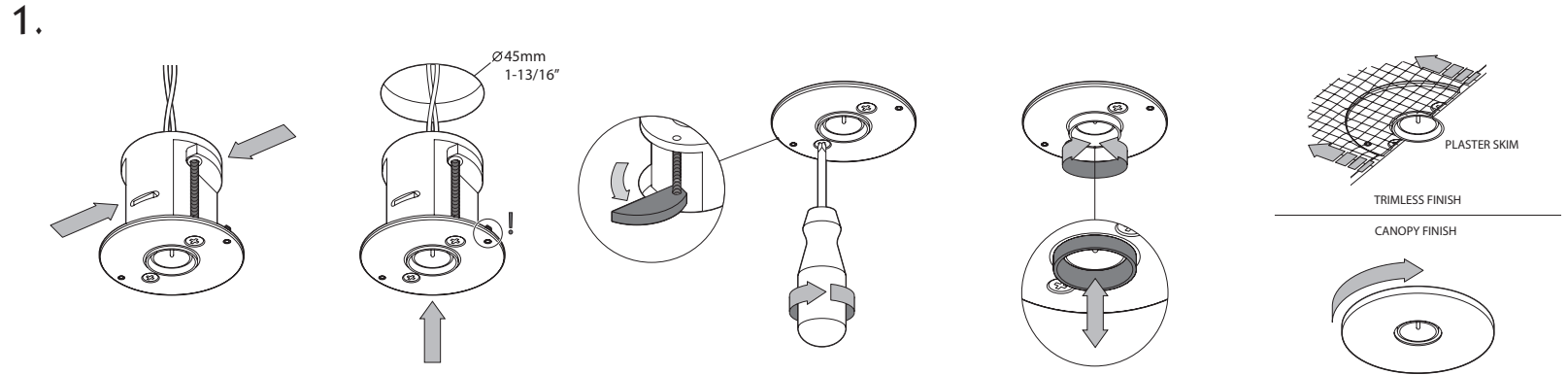

2. Flat Monopoint [MPX].

- Insert monopoint in $\text{\O}25\text{mm}$ (1 inch) ceiling hole and fasten in place using screws provided.
- Attach Decorative canopy, screwing clockwise to secure.

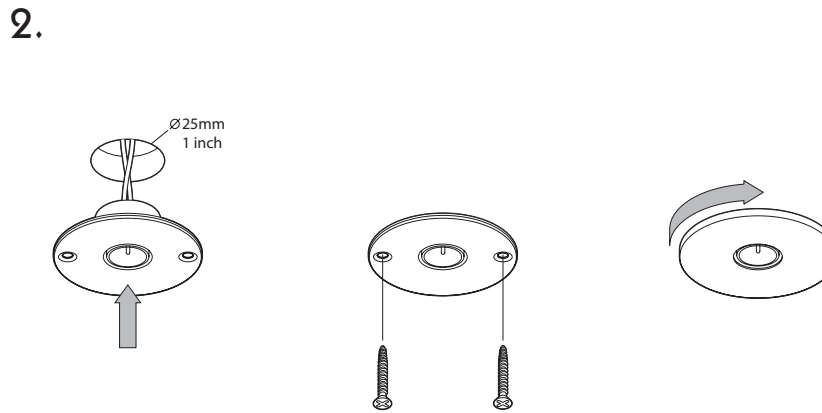

3. Node Monopoint [MPY].

IMPORTANT node monopoint must be installed before wiring up. Maximum material thickness is 12mm (1/2 inch).

- Remove retaining nut.
- Insert monopoint in $\text{\O}25\text{mm}$ (1 inch) hole and fasten in place using retaining nut.

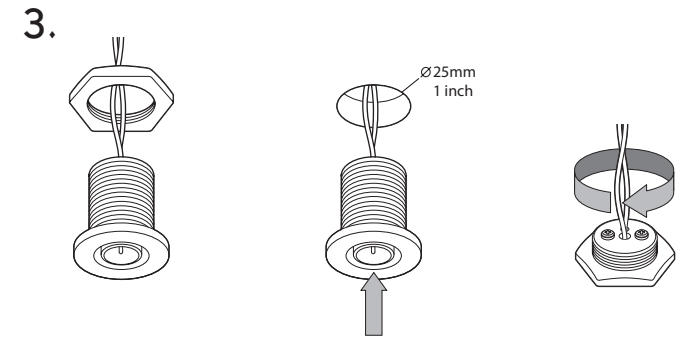

4. Surface Monopoint [MPZ].

- Unscrew outer casing anti-clockwise to remove.
- If no rear access is available, remove rear channel and secure in place, running cables out the side of the monopoint.
- If rear access is available, secure in place using screws provided.
- Replace outer casing by screwing clockwise to secure.

